

Low Pass Filter

Model No : ALF - 400P

SPECIFICATIONS:

ELECTRICAL

Pass Band Frequency	:	225 - 400 MHz
Power handling capacity	:	150 watts (average)
Insertion Loss (over pass band)	:	0.6 dB (max)
Return Loss (over pass band)	:	17 dB (min)
Impedance	:	50 ohms
Stop Band Attenuation @ 450 to 1000 MHz	:	50 dB (min)

MECHANICAL

Over all dimensions	:	98.4 X 48.8 X 25.4 mm (3.87" X 1.92" X 1")
Connectors	:	SMA Type Female
Operating temperature	:	-10 ⁰ C to + 55 ⁰ C

Outline Drawing:

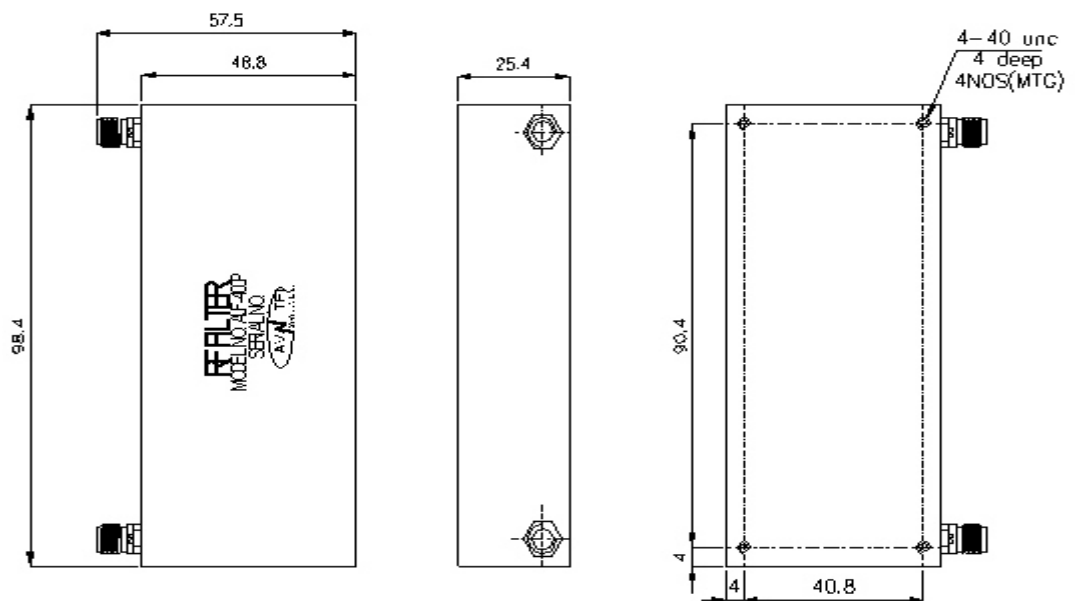

All dimensions are in millimeters

Avantel Limited