

SINGLE HOP BAND SELECTIVE REPEATER

Model No : ASR - 1800 - 33H-RF

DESCRIPTION:

The repeater system is a two-way amplifier that provides booster performance to extend the coverage of radio communications in buildings, basements and other RF shadow areas. The Repeater receives signals from one antenna, amplifies them and transmits through the other antenna.

This enlarges coverage of cellular base stations.

Features such as high linearity amplifier characteristics, and sharp out of band rejection duplexers, assist in avoiding interfering signals & makes it an ideal solution for in-building installation.



Block Diagram:

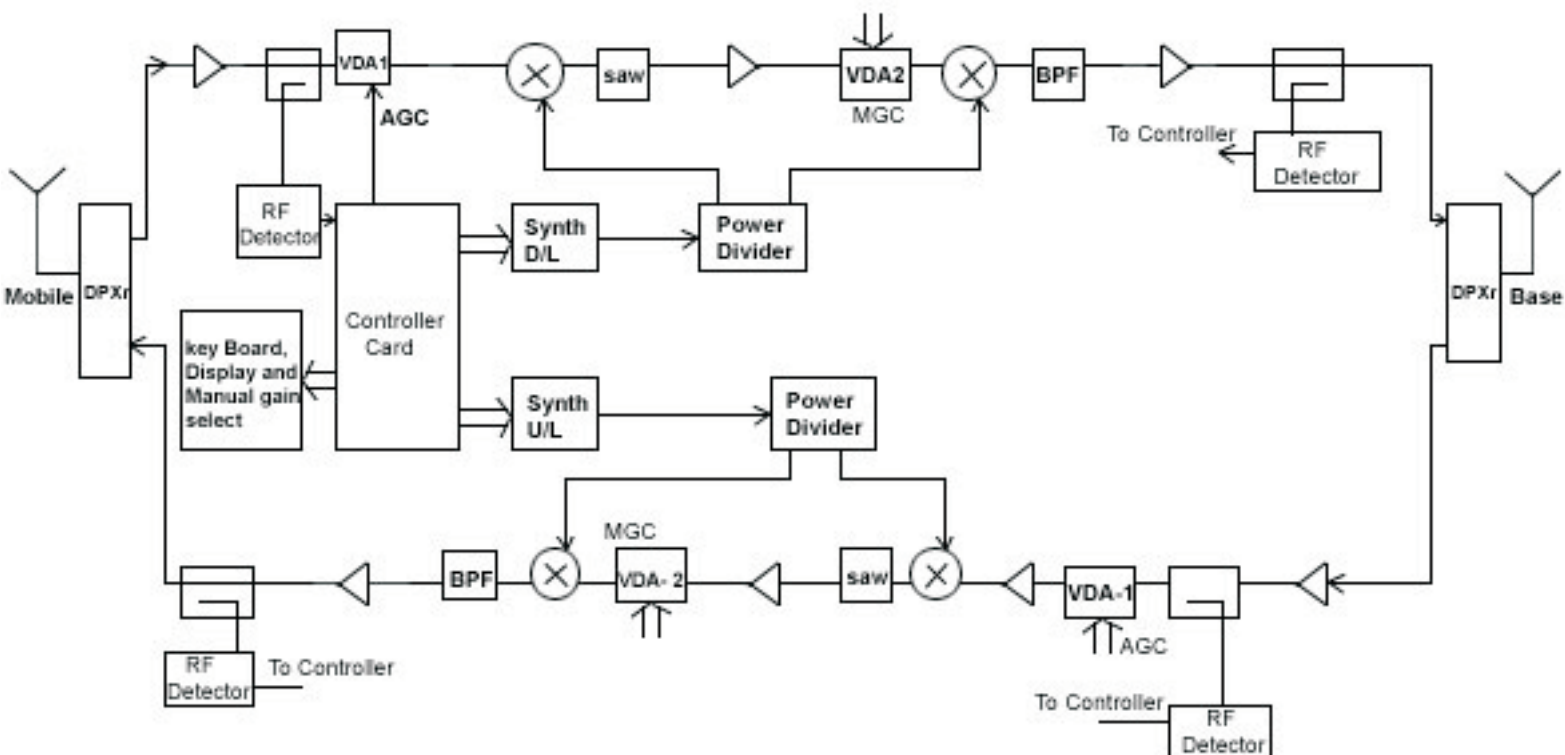

SINGLE HOP BAND SELECTIVE REPEATER

Model No : ASR - 1800 - 33H-RF

Main Features:

- In-Building Solution
- Exceptionally linear operation
- Manual gain control
- Cost Effective Solution
- Wall mounted easy installation
- Out door application

SPECIFICATIONS:

Up Link Frequency	:	1710 - 1785 MHz
Down Link Frequency	:	1805 -1880 MHz
Band Width	:	User Specified
Pass Band Gain	:	85 dB \pm 1 dB
Manual Gain Adjustment	:	30 dB in 1 dB steps
Power Output	:	33 dBm
Noise Figure	:	< 8 dB
Delay	:	< 6.5 μ Sec.
In/Out Impedance	:	50 ohms
RF Connectors	:	N Female
Supply Voltage	:	180 - 260 V Ac
Operating temperature	:	0° to +50° C

Regd. & Corporate Office

Plot No. 16, Sector-III, HUDA Techno Enclave,
Opp. K. Raheja IT Park, Madhapur,
Hyderabad - 500 081, India.
Tel : +91-40-2311 5050/51/52
Fax : +91-40-2311 2336

Production Unit

Sy. No. 227 & 229, Plot No. 31, Phase-II
IDA, Cherlapally, R.R. District,
Hyderabad - 500 051, India.
Tel : +91-40-2726 2999, 6458 5519
Fax : +91-40-2726 2888

Avantel Limited

www.avantel.in
info@avantel.in