

Single Hop GSM 900 MHz, 85 dB gain, 33 dB Out put Band Selective Repeater

Model No : ASR - 900 - 33H

DESCRIPTION:

The repeater system is a two-way amplifier that provides booster performance to extend the coverage of radio communications in buildings, basements and other RF shadow areas. The Repeater receives signals from one antenna, amplifies them and transmits through the other antenna.



This enlarges coverage of cellular base stations.

Features such as high linearity amplifier characteristics, and sharp out of band rejection duplexers, assist in avoiding interfering signals & makes it an ideal solution for in-building coverage solution as well as outdoor coverage solution.

Block Diagram:

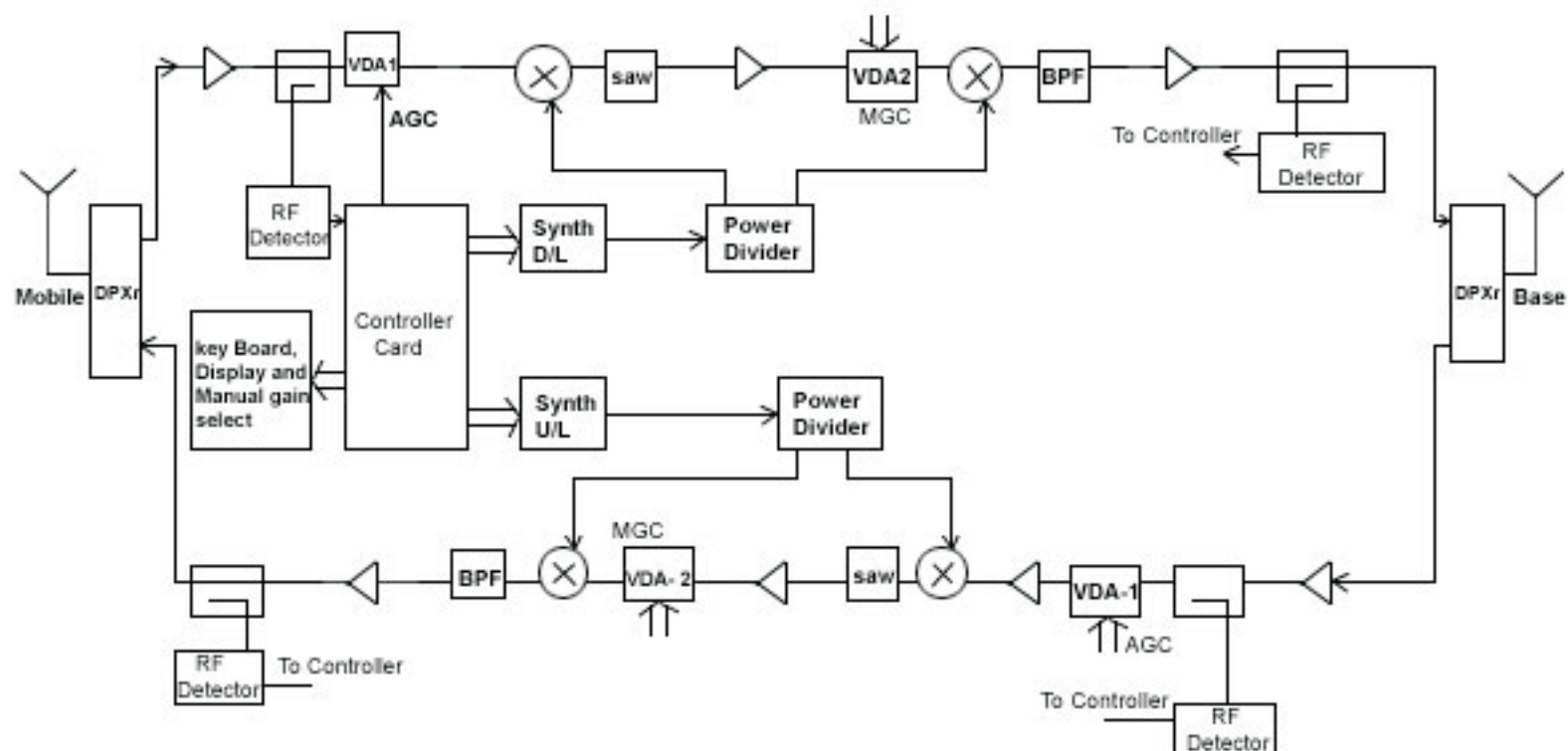

Single Hop GSM 900 MHz, 85 dB gain, 33 dB Out put Band Selective Repeater

Model No : ASR - 900 - 33H

SPECIFICATIONS:

Up Link Frequency	:	890 - 915 MHz
Down Link Frequency	:	935 - 960 MHz
Band Width	:	6.2 MHz / Available upon Request
Pass Band Gain	:	85 dB \pm 1.5 dB / Available upon Request
Manual Gain Adjustment	:	30 dB in 1 dB steps
Power Output	:	33 dBm
Noise Figure	:	< 8 dB
Delay	:	< 6.5 μ Sec
In/Out Impedance	:	50 ohms
Return Loss	:	> 10 dB
RF Connectors	:	N Female
Supply Voltage	:	90 - 260 V Ac, 47 to 440 Hz
Operating temperature	:	0° to +50° C

Options:

1. AGC Range : 30 dB
2. Key Pad and Display for programmability.

Regd. & Corporate Office

Plot No. 16, Sector-III, HUDA Techno Enclave,
Opp. K. Raheja IT Park, Madhapur,
Hyderabad - 500 081, India.
Tel : +91-40-2311 5050/51/52
Fax : +91-40-2311 2336

Production Unit

Sy. No. 227 & 229, Plot No. 31, Phase-II
IDA, Cherlapally, R.R. District,
Hyderabad - 500 051, India.
Tel : +91-40-2726 2999, 6458 5519
Fax : +91-40-2726 2888

Avantel Limited

www.avantel.in
info@avantel.in