

GSM 1800 RF REPEATER

Model No : ACR - 1800

DESCRIPTION:

The repeater system is a two-way amplifier that provides booster performance to extend the coverage of radio communications in buildings, basements and other RF shadow areas. The Repeater receives signals from one antenna, amplifies them and transmits through the other antenna. This enlarges coverage of cellular base stations.



Features such as high linearity amplifier characteristics, and sharp out of band rejection duplexers, assist in avoiding interfering signals & makes it an ideal solution for in-building installation.

Main Features:

- In-Building Solution
- Linear Operation
- More Gain in Downlink Chain
- Manual Gain Adjustment Facility
- Compact size
- Cost Effective Solution
- Ease of Installation

Avantel Limited

GSM 1800 RF REPEATER

Model No : ACR - 1800

Block Diagram:

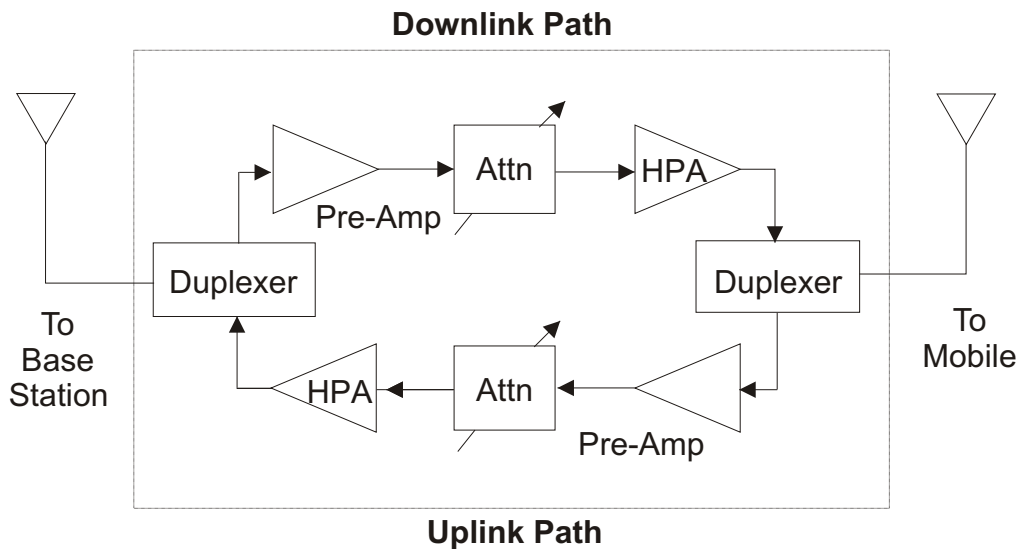

SPECIFICATIONS:

Downlink	Uplink
Frequency Range : 1805 to 1880 MHz	Frequency Range : 1710 to 1785 MHz
Pass Band Gain : 60 ± 1 dB	Pass Band Gain : 55 ± 1 dB
Freq. Response : ± 1.5 dB	Freq. Response : ± 1.5 dB
Manual Gain Adjustment : 30 dB	Manual Gain Adjustment : 30 dB
Output power : +19 dBm	Output power : +19 dBm
Impedance : 50	Impedance : 50
Return loss : >10 dB	Return loss : >10 dB

RF Connectors : N(F)
 Supply Voltage : 230 V AC
 Operating Temperature : 0 to +50 deg
 Size : 300 x 200 x 120 mm
 Weight : 6 kg

Avantel Limited